

## 1 Link-State Routing

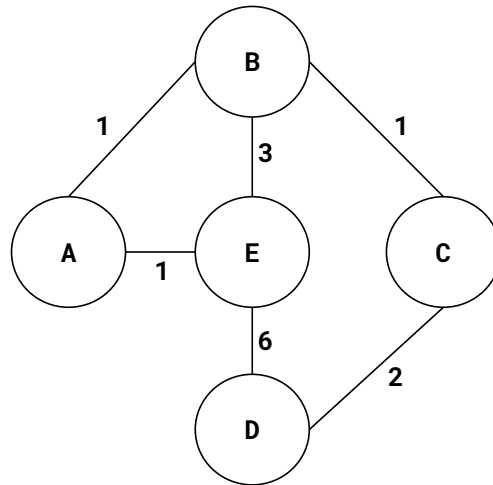

- (1) E begins to calculate its shortest paths to all other routers. Fill in the following table that contains routing information for E. Columns represent destination routers. You may use any shortest path algorithm (i.e. Dijkstra's) to calculate shortest paths.

	A	B	C	D
Shortest path (i.e. $E \rightarrow A \rightarrow B$ )				
Path cost				

- (2) Assuming all other routers have also computed their shortest routes, what path does a packet take from E to D?
- (3) Assume that the cost of the link between C and D suddenly increases from 2 to 20, and routing has not yet re-converged. Is it possible that packets now enter a loop?

## 2 IP Header

IPv4 and IPv6 have very different headers. In particular, IPv6 dropped many of the fields that IPv4 headers had. Why did IPv6 drop the following fields from its header?

- (1) Checksum:

(2) Header Length:

(3) Fragmentation:

(4) IPv6 also hosts much larger address fields (128 bits). Is that enough bits, or might some future IPvN need to expand these fields further?

### 3 Putting it All Together

Host A in AS 1 wants to communicate with host B in AS 2. This problem will walk through many of the various steps necessary for this to happen.

#### 3.1 BGP

Consider the network topology below. Assume all ASes are following Gao-Rexford policies. Arrows point from providers to customers (e.g. AS X is a provider to AS 1).

Solid lines denote peering (e.g. AS 1 is peered with AS W)

Dotted lines connect individual hosts to their ISP's AS (e.g. A's ISP is AS 1)

#### Gao-Rexford Rules

- Export policy: To customers export all routes. To peers and providers only export routes to customers.
- Selection policy: pick routes in the following order: Customers Peers Providers.

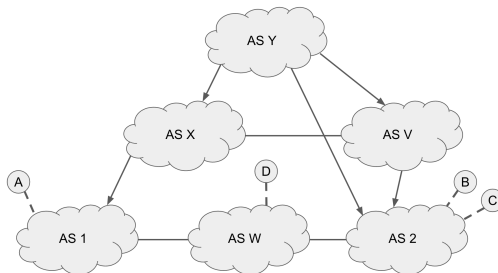

(1) What path does AS1 use to reach AS2?

(2) AS Y would export routes for which hosts to AS X?

- (3) AS 2 is a customer of both AS V and AS Y. What is the general term for having multiple providers in this fashion?

### 3.2 Address Allocation

Assume that AS X has the prefix 1.2.240.0/16 and plans to give some portion of this address space to its customers (AS 1).

- (1) AS 1 wants to be able to support up to 1,000 hosts in its AS. What is the maximum prefix length AS 1 could use?
- (2) Assume AS X has another customer AS to which it allocates the block 1.2.248.0/24 (not pictured). How many hosts can this AS support?
- (3) Will any of these allocation decisions for AS X's customers affect the routing tables for AS Y (AS X's provider)?

### 3.3 BGP Selection

Suppose that the AS topology is the same as question 2.1 except Assume ASes X and V no longer peer, and that AS W becomes another provider to both AS1 and AS2.

Suppose that the internal network topology of AS1 is as follows

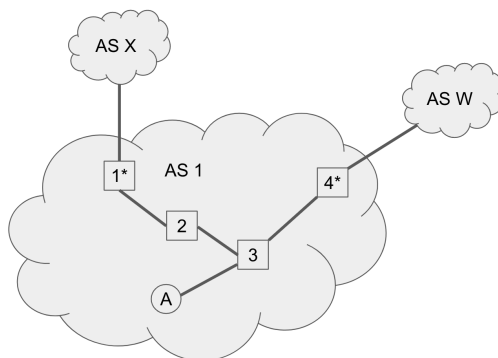

The goal of this question is to test your understanding on BGP and its connection to routing algorithms.

Note that the *LocalPrefs* represent preferences for AS paths. The paths listed in the table have been abbreviated to the last hop AS. **The table contains exports for destination B.**

Routers	<i>LocalPref</i>	<i>ASPATH</i>	<i>IGP path</i>	<i>MED</i>
1	ASX:5, ASW:1	-	-	-
2	ASX:5, ASW:1	-	-	-
3	ASX:3, ASW:2	-	-	-
4	ASX:2, ASW:3	-	-	-

- (1) Suppose that host A is connected to 3 and wants to send a packet to B. Which path does the packet take?
- (2) Suppose now that all routers have the same local pref for each autonomous service and A is still connected to router 3. Given the ASPATH's below which path would A's packet to B take? **NOTE:** the ASPATH routing state has not converged yet.

Routers	<i>LocalPref</i>	<i>ASPATH</i>	<i>IGP path</i>	<i>MED</i>
1	ASX:5, ASW:5	ASX-ASY-AS2	-	-
2	ASX:5, ASW:5	ASX-ASY-AS2	-	-
3	ASX:5, ASW:5	ASW-AS2	-	-
4	ASX:5, ASW:5	ASW-AS2	-	-

- (3) Now suppose that all routers have the same local pref, the ASPATHs have converged, and each link has a cost of 1. Which AS does the packet go through?

### 3.4 Learning Switches in AS2

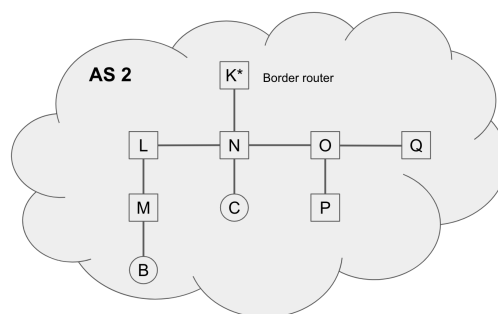

For this question, *K* is AS2's single border router connecting to all other ASes from question 2.1. Assume that internally, AS2 is running the learning switch algorithm for IGP. All routers in the network start with empty forwarding tables.

- (1) *K* forwards A to B, which routers receive this packet?

(2) C sends a packet to B, which routers receive this packet?

(3) B responds to A, which switches receive this packet?